



**HULON** by **CONFIDENCE AND LIGHT**



# HULON

APPLIQUE, BANDEAU, CORNICHE  
WALL-MOUNTED, STRIP & CORNICE LUMINAIRES

## DESCRIPTION / DESCRIPTION

- Éclairage indirect seul
  - 2 lampes fluorescentes compactes (36,55 ou 80 W) ou 2 tubes fluorescents (28, 35, 54 ou 80 W)
  - Ballast électronique dimmable
  - Verre trempé anti-poussière
  - Perforations décoratives « ciel étoilé » en sous face
  - Carrés de couleur en face avant
- *Indirect light emission only*
  - *2 fluorescent compact lamps (36, 55 or 80 W) or tubes (28, 35, 54 or 80 W)*
  - *HF electronic control gear*
  - *Anti-dust hardened float glass*
  - *Decorative «starry sky» perforations on the under side*
  - *Coloured squares on the front*

## LES FINITIONS / FINISHES



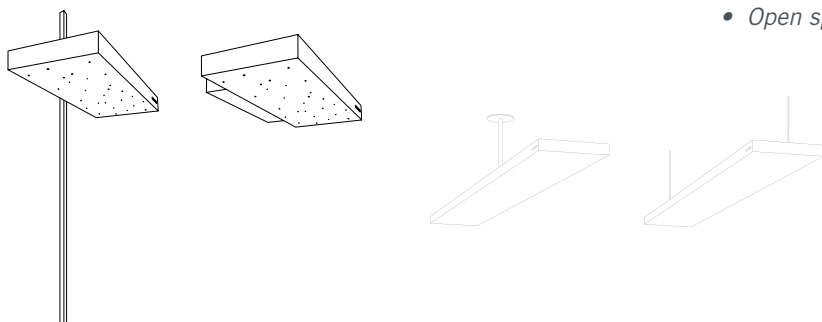

- Blanc 
  - Argent 9006 satiné 
  - Autre couleur sur demande
  - Perforations en face avant 
- *Powder coated satin white*
  - *Powder coated satin silver (9006)*
  - *Other colours on request*
  - *Perforations on the front*



## LES VERSIONS / VERSIONS

- Appliques murales
  - Bandeaux avec mise en jonction ou isolés
  - Appliques sur mâts techniques
  - Appliques à poser
  - Adaptation sur mobilier
  - Corniches (fixation directe sur la paroi sans boîtier mural)
- *Wall-mounted*
  - *Strip lights (joined together or isolated)*
  - *Mounting on power poles*
  - *Adaptations on furniture*
  - *Cornice lights (direct mounting on the wall without wall box)*

## LES OPTIONS / OPTIONS

- Relais électronique de relance 
  - Commande à distance radio 
  - Détection de présence/capteur de luminosité EcoDim 
  - Commande par boîtier déporté 
- *Electronic timer switch*
  - *Radio transmission technology*
  - *EcoDim sensor/light sensitive cell*
  - *Remote control*

## APPLICATIONS SPÉCIFIQUES / SPECIFIC APPLICATIONS

- Éclairage tertiaire
  - Circulations
  - Bibliothèques
  - Salles d'archives
  - Espaces ouverts sur mâts techniques
- *Office lighting*
  - *Corridors*
  - *Libraries*
  - *Archives areas*
  - *Open spaces on power poles*



# HULON FICHE TECHNIQUE

TECHNICAL DATA SHEET

## DIMENSIONS / DIMENSIONS

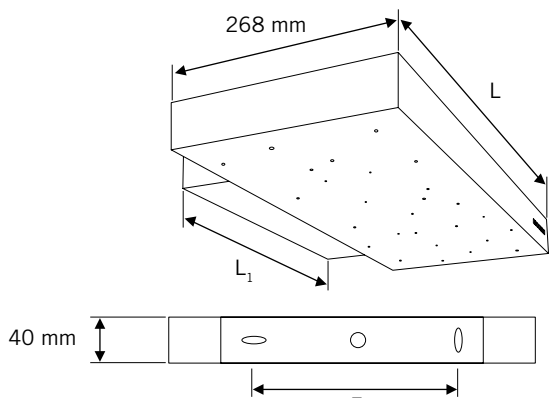

Appliques - Bandeaux (avec boîtier interface sur la paroi)  
 Wall-mounted luminaires - Strip lights (with interface box on the wall)

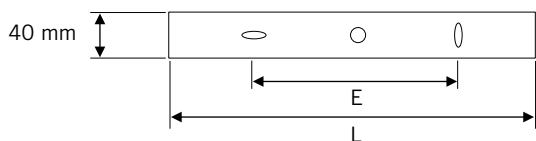

Corniches (fixation directe sur la paroi sans boîtier mural)  
 Cornice lights (Mounting directly on the wall without wall box)

## PHOTOMÉTRIE & NORMES PHOTOMETRY & STANDARDS

- Classe 1 IP 20 850°
- NF-EN 60.598-1 Luminaires  
 Règles générales et généralités sur les essais
- NF-EN-60.598-2.1 Luminaires  
 Règles particulières section un - luminaires fixes à usage général

- Class 1 IP 20 850°
- NF-EN 60.598-1 - luminaires  
 General rules and general points about the tests
- NF-EN-60.598-2.1 luminaires  
 Special rules section one - fixed luminaires for general use

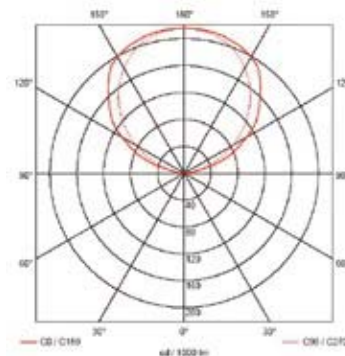

## LES RÉFÉRENCES / ARTICLE NUMBER

| Désignation<br>Description  | Référence<br>Article number | Équipement<br>Equipment | Culot<br>Lampholder | Longueur<br>Length<br>mm (L) | Boîtier mural<br>Wall box<br>mm (L1) | Nombre points<br>fixation / Number<br>of fixing points | Entraxe entre les points<br>de fixation / Distance<br>between the points - mm | Poids<br>Weight<br>(kg) |
|---|-----------------------------|-------------------------|---------------------|------------------------------|--------------------------------------|--|---|-------------------------|
| Appliques lampes<br>fluorescentes<br><i>Wall-mounted luminaire<br/>Fluorescent lamp</i> | A.H.236...                  | 2X36 W                  |                     | 490                          | 300                                  | 2  | 246   | 5                       |
|   | A.H.255...                  | 2X55 W                  | 2G11                | 590                          | 300                                  | 2  | 246   | 5                       |
|   | A.H.280...                  | 2X80 W                  | 2G11                | 660                          | 300                                  | 2  | 246   | 6                       |
| Appliques tubes<br>fluorescents<br><i>Wall-mounted luminaire<br/>Fluorescent tube</i>   | A.H.228...                  | 2X28 W                  |                     | 1300                         | 980                                  | 5  | 222   | 10                      |
|   | A.H.235...                  | 2X35 W                  | G5                  | 1600                         | 980                                  | 5  | 222   | 11                      |
|   | A.H.254...                  | 2X54 W                  | G5                  | 1300                         | 980                                  | 5  | 222   | 10                      |
|   | A.H.280.G5....              | 2X80 W                  | G5                  | 1600                         | 980                                  | 5  | 222   | 11                      |

Interface de jonction *Set for linear mounting* A.H.JX...

Bandeau *Strip lights* B.H...

Corniche *Cornice Lamps* CL.H...

## CONFIDENCE AND LIGHT

www.confidenceandlight.com

### Siège Social

3, rue Boch - BP 41  
 45240 La Ferté Saint-Aubin France  
 Tél. + 33 (0)2 38 76 67 75 Fax + 33 (0)2 38 49 63 82  
 contact@confidenceandlight.com

### Agence Paris

86, rue du Cherche-Midi 75006 Paris France  
 Tél. + 33 (0)1 42 22 35 35 Fax + 33 (0)1 42 22 35 36  
 paris@confidenceandlight.com